

Ocellaris 400

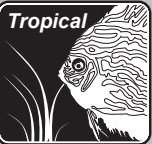

2+1
YEAR
GUARANTEE



Instruction version: 30/06/2014

www.aquaone.com.au

Important Safeguards

To guard against injury, basic safety precautions should be observed, including the following:

1. Read and follow all safety instructions and important notices in these instructions as well as on the product itself.

2. This appliance is not intended for use by children or infirm persons without supervision. Young children should be supervised to ensure that they do not play with the appliance.

3. To avoid possible electric shocks, special care should be taken since water is employed in the use of aquarium equipment. For each of the following situations do not attempt repairs yourself. Return the appliance to an authorised service facility for service or discard the appliance.

a. If the appliance or any electrical component of the appliance (non-immersible equipment only) falls into the water or gets wet, do not reach for it. Unplug it and then retrieve it.

b. If the appliance shows any sign of abnormal water leakage, immediately unplug it from the power source.

c. Carefully examine the appliance after installation. It should not be plugged in if there is water on parts which are not intended to be wet.

d. Do not operate the appliance if it has a damaged cord or plug, or if it is malfunctioning, or dropped or damaged in any manner.

4. A “drip loop” (see graphic) should be arranged for each cable connecting an aquarium to a power supply. The drip loop is the part of the cable below the level of the power supply. It prevents water travelling down the cable and coming into contact with the power supply. If the plug or the socket does get wet, do not unplug the appliance. Disconnect the fuse or circuit breaker that supplies the power to the appliance, then unplug and examine for presence of water in the socket.

5. Always unplug the appliance from the electrical outlet when not in use, before putting on or taking off parts, before any type of maintenance or cleaning.

6. Never yank the cable to pull it from the socket. Pull the plug carefully to disconnect.

7. Do not use the appliance for reasons other than the intended use. The use of attachments that are not recommended or sold by the manufacturer may cause the product to be unsafe. This is not recommended.

8. Do not install or store the appliance where it will be exposed to weather or temperatures below freezing.

9. Make sure any component mounted on a tank is securely installed before operating it.

10. Ensure input voltage is the same voltage as your local power supply.

11. If an extension cable is used it should have the proper rating. Care should be taken to arrange the cord so that it will not be tripped or pulled.

12. A G.F.C.I (Ground fault circuit interrupter) & surge protector is recommended for all electrical appliances.

13. Ensure your hands are dry when turning the power switch on/off and when inserting/removing the power cable from the socket.

14. If you are in any doubt about the electrical installation or safety of this product you must consult a qualified electrician.

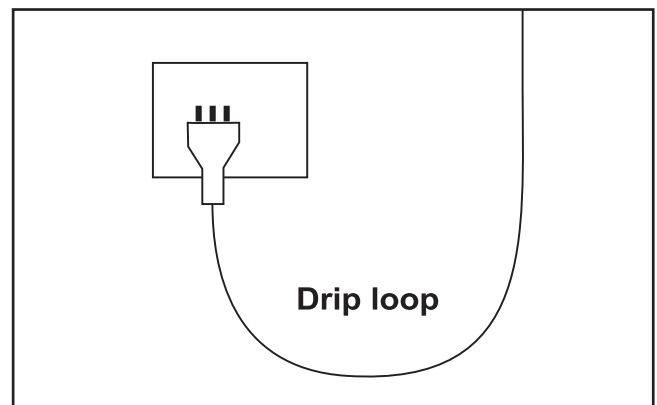

For Guarantee Conditions, please refer to the Guarantee form that is enclosed with this product.

All products are supplied with fitted plugs. This plug should not be tampered with in any way or removed. Removal or tampering with the plug invalidates our guarantee offered with this product.

For UK a 3 pin adaptor is supplied with the product and this must be used.

Before First Use / Preparation

Read and follow all the instructions, even if you feel you are familiar with the product and find a place to keep the instructions handy for future reference. Your attention is drawn particularly to the sections concerning **“IMPORTANT SAFEGUARDS”** and the **“GUARANTEE CONDITIONS”**. Please ensure you retain your original purchase receipt in the event that guarantee service is required.

Carefully unpack the filter making sure you keep all the packing material until all the parts of the product have been found and the product has been assembled.

This product is shipped to you in a factory sealed carton. Should the product malfunction in any way or if the unit is damaged and requires replacement, contact the retailer where the product was purchased for inspection.

Know Your Filter

Canister Filter 400

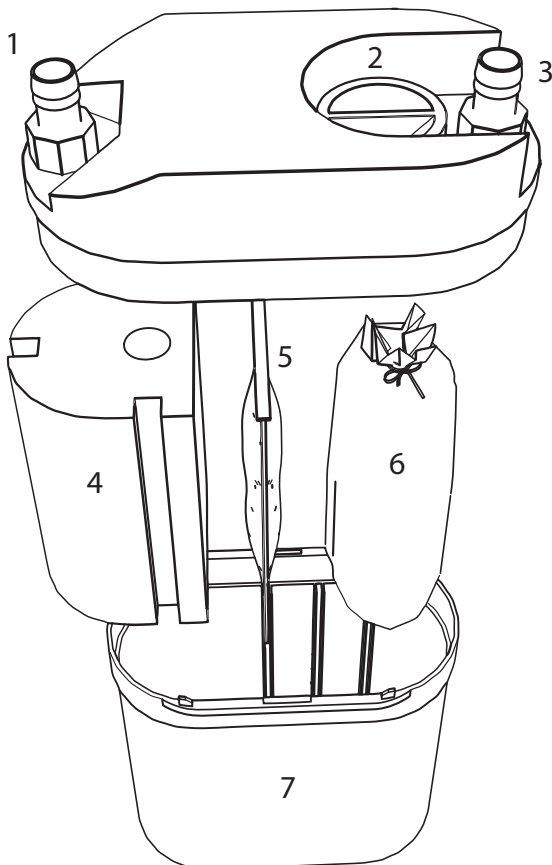

Replacement Parts & Filter Media

Use Aqua One Genuine Spare Parts Only. See your local Aqua One Dealer and look for the number listed below for the spare part you require. Alternatively you will find these numbers on the silver label located on the product.

400 Impeller	143I
400 Wool Cartridge	143W
400 Sponge	143S

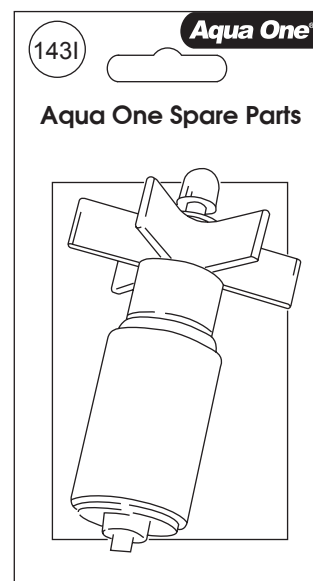

Set up/Parts

1. Outlet
2. Priming Cap
3. Inlet
4. Sponge
5. Wool Cartridge
6. Sintered Glass Noodles
7. Canister Body

Recommended Filter Media Set Up

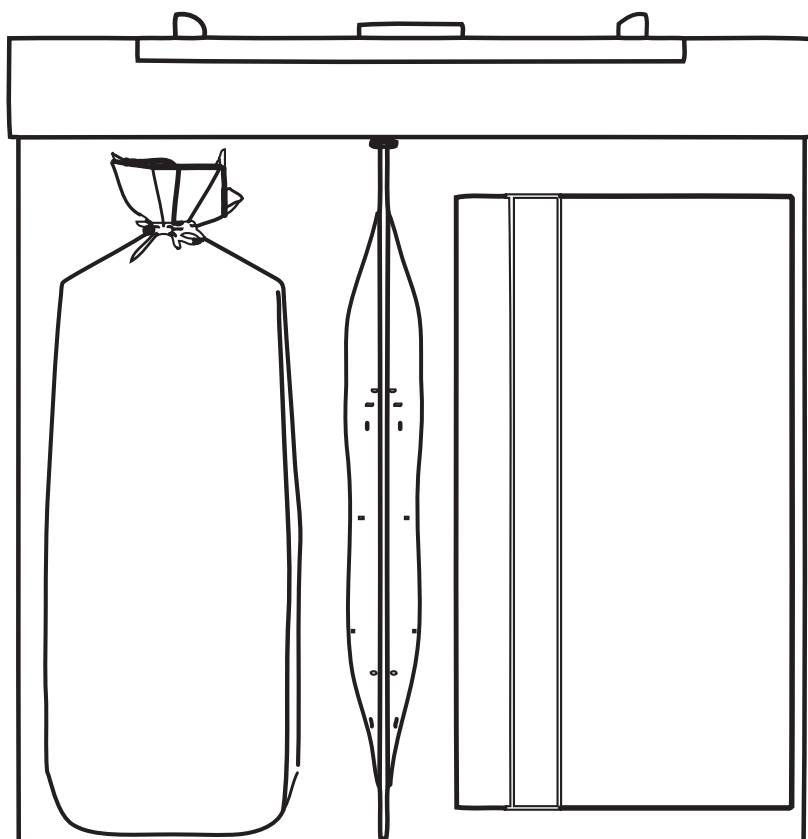

- 1. Ceramic Noodles
- 2. Wool Cartridge
- 3. Sponge
(Black 35ppi)

Inlet/Outlet Parts

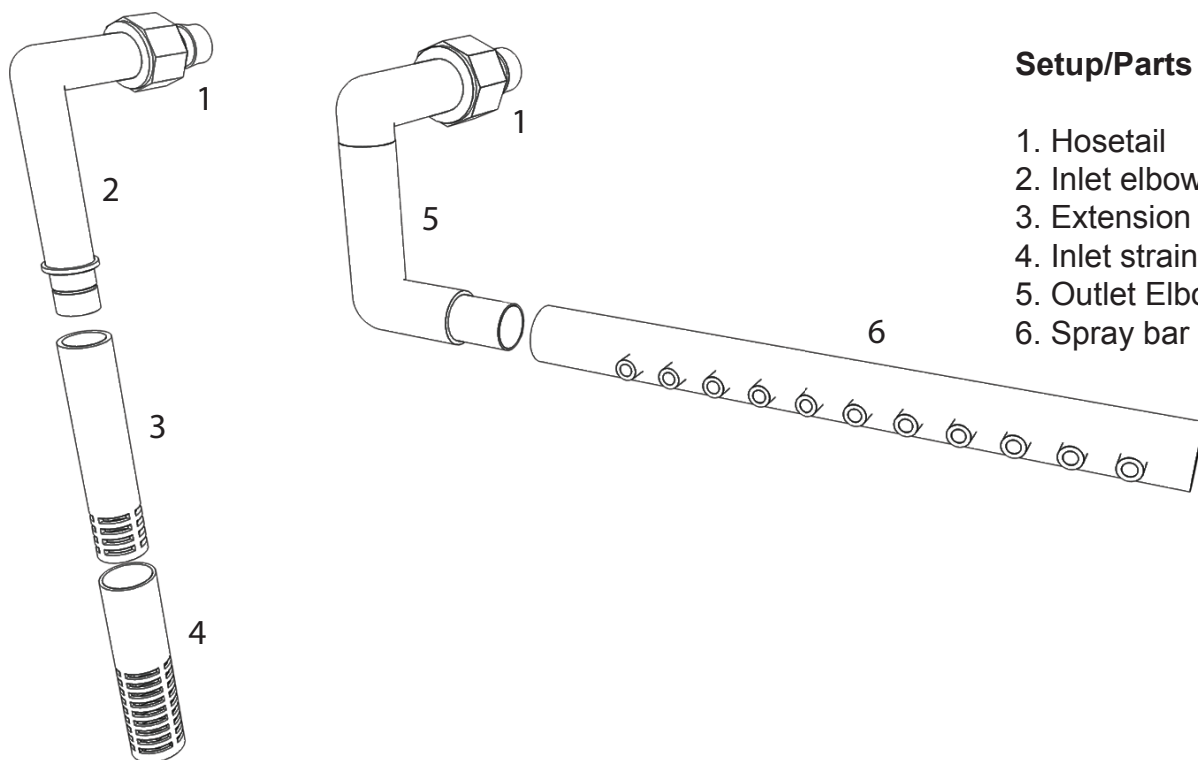

Setup/Parts

- 1. Hosetail
- 2. Inlet elbow
- 3. Extension pipe
- 4. Inlet strainer
- 5. Outlet Elbow
- 6. Spray bar

Set Up Instructions

Filling with Media

1. Open the filter unit by releasing the 2 clips located on either side of the filter, then lift the head unit off the canister body.
2. Remove the filter media from the canister. Rinse the filter media in tap water to remove excess dust and place it back into the filter according to the media set up illustrated on page 4.

Checking the function

3. Prior to installing the head unit, connect it to the power supply. You should be able to see the impeller spin. If there are any problems refer to the Trouble Shooting Section. Disconnect from the power supply after a few seconds to avoid damaging the powerhead.

Replacing the head unit

4. Line the filter outlet pipe up with the feeder pipe on the base of the head unit.
5. Press down gently, the bottom of the head unit should be flush with the canister body. Be careful not to jam the power cord in between the canister and the head unit. Do not force it together! If it feels tight do not apply any pressure to close it. Simply, remove the head unit and try again.
6. Latch and secure the clips. The filter unit is now ready to be installed.

Installing the tap connectors and hose pipes

7. Two hoesails (IN and OUT) are located at the top of the filter unit. You will need two pieces of hose. Screw the collar on the taps all the way in clockwise.
8. Now push one end of the hose over the hose tail and thread. Push it on as far as possible. Then turn the collar anti clockwise to lock in the hose. Repeat for the other hose.
9. Place the canister in the desired position and feed the hose through the cabinet or stand.

Assembling the inlet and outlet pipes

Refer to diagram on page 4.

OUTLET

10. Connect the Spray Bar (6) to the Outlet Elbow (5).
11. Using the supplied suction cups, attach the spray bar to the back or side of the aquarium with the hoesail sitting above the rear glass of the aquarium.

INLET

12. Attach the Inlet Strainer (4) and Extension Pipe (3) to the Inlet Elbow (2).
13. Using the supplied suction cups, attach the intake pipe to the back of the aquarium with the hoesail sitting above the rear glass of the aquarium.
14. Pull the hose from the inlet side of the filter up next to the inlet hoesail and line up.
15. Measure a good 5cm more than what you need past the bottom of the hoesail.
16. Cut the hose using a sharp blade, try to cut it straight and be careful not to cut yourself.
17. Screw the collar on the pipe all the way in clockwise. Force the hose over the inlet hoesail. Then turn the collar anti clockwise to lock in the hose. Tighten, hand tighten only, no tools are required.
18. Repeat for the outlet pipe. You are now ready to start the filter.

Starting Your Filter

Method 1

1. The primer for your canister filter is located at the top of the head unit. Open the primer by unscrewing the cap. Fill the canister using water siphoned from the aquarium or use a clean water jug (add water conditioner if using tap water). Fill the canister slowly as it may be difficult to judge when the filter is full. Once the canister is full, replace the cap.

2. Now the canister filter is ready to be plugged in.

3. Due to the volume of water in the canister filter, it may be necessary to top up the water in the aquarium, particularly if water has been siphoned from the aquarium to the filter. Add water conditioner to water that is added.

Method 2

1. Temporarily detach the outlet from the tubing and create a siphon by sucking on the tube. Once the siphon begins, lower the outlet tube into a bucket.

2. Wait until the canister is completely full of water. You will know this when the water starts to flow into the bucket.

3. Place your thumb over the open end of the tubing and affix the outlet pipe to your aquarium.

4. Now the canister filter is ready to be plugged in.

5. Due to the volume of water in the canister filter, it may be necessary to top up the water in the aquarium. Add water conditioner to water that is added.

Maintenance

1. Turn the canister filter off at the socket and unplug.
2. Place a towel or a shallow container under the canister unit. This will prevent any water spilling onto your cabinet or stand and damaging it.
3. Fill a bucket with water from your aquarium and take it to the sink or wherever you intend to clean your filter. Keep in mind cleaning your filter can be messy, cleaning is recommended outside or at a sink. Ensure the area is clean and free from soaps and detergents.
4. Open the canister. Release the 4 clips and remove the head unit, place it somewhere safe where it will not be trodden on or broken.
5. Remove the sponge, noodles and wool cartridge from the canister body.
6. Pour the water from the canister body out of the filter, ensuring none of the media is lost. Using the bucket of aquarium water, fill the canister enough that the media is submerged. Shake the canister gently to rinse the media. Empty the water from the filter. Repeat this until the water being emptied is clean.
7. Either replace or rinse the white wool cartridge using a high pressure hose. It should be replaced regularly or when it begins to deteriorate and can no longer be cleaned properly.
8. The sponge and noodles can also be rinsed in the bucket of aquarium water (refill from the aquarium if necessary). The sponge will also require replacement eventually as over time it will clog and prevent water from traveling through easily.
9. Place the media back into the correct position in the canister body.
10. The impeller should also be cleaned whenever the filter is disassembled.
11. Turn the head unit over, remove the screws in the impeller cover and remove it.

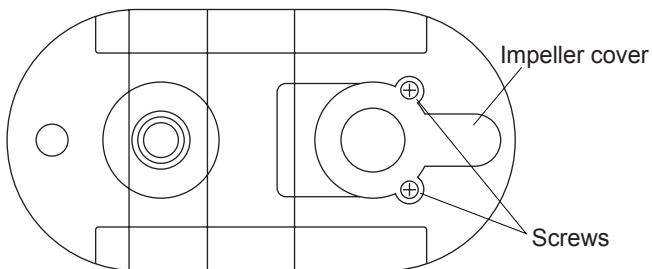

12. Then pull the impeller cap off and remove the impeller.

13. Clean the impeller chamber using a double ended pipe brush.
14. Pull the rubber end cap off the shaft of the impeller and run water through the hole in the middle of the impeller. Clean any debris which may have built up on the shaft off, along with any slime build up on the impeller.

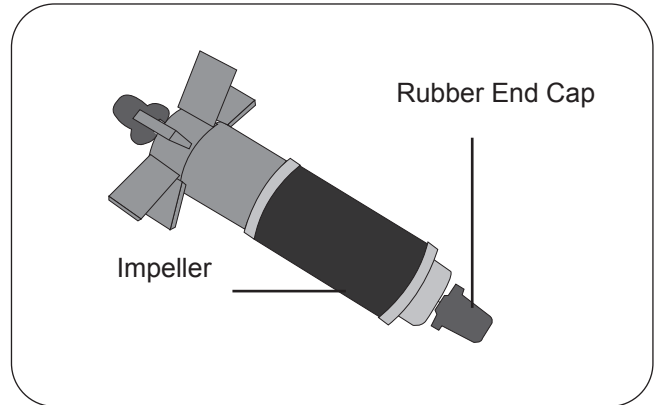

15. Put the impeller back together and ensure that it rotates freely on the shaft. Then reassemble the head unit, ensure there is no water on the power cord, plug the head unit in and turn on. Make certain the impeller is spinning. Turn it off. Reassemble the filter unit. Apply an aquarium safe lubricant to the O-ring on the head unit. This will provide a better water seal and make the removal of the head easier next time the filter has to be disassembled for maintenance.
1. Check your inlet, outlet tubes and hoses. If residue has built up on the inside of them remove them from the aquarium. Take to the sink, run hot water through them to loosen the slime. Run a double ended pipe brush through them, and flush again with hot water. This build up will reduce the flow rate of your filter considerably, so clean whenever it is possible.
20. Return the canister filter to your cabinet or stand and reattach the hoses.
21. Refer to the section in this instruction manual Starting You Filter for details on restarting the unit

Trouble Shooting

The filter unit is leaking

1. Check that all o-rings are in place and that they are not damaged or soiled.
2. Apply aquarium safe lubricant to o-rings.
3. Ensure the head unit is locked securely in position.

The filter will not prime

1. Check the tubing for kinks.
2. Check that the aquarium is filled with water.
3. Make sure that the intake pipe and/or intake strainer are not blocked.
4. Ensure that the hoses are connected to the unit correctly. Intake strainer to IN and spray bar to OUT.

The filter will not start

1. As previous tips.
2. Check the impeller and shaft are in good condition.
3. Ensure the filter is plugged in.

Low water flow

1. As both previous tips.
2. Clean or replace the filter media.
3. Clean the inlet and outlet hoses.
4. Clean all tubing.

Both water & air coming from the outlet pipe

1. Leave for 3-5 minutes.
2. Make sure that no air stone is operating near the intake strainer.
3. Check all tubing is connected firmly.
4. Check all o-rings and re-apply aquarium safe lubricant.
5. Gently rock the filter back and forth trying to discharge the air in the canister.

The filter is making noise

1. As per previous tips
2. Outlet or inlet flow is restricted. Check tubing.



Specifications

Canister Model: Ocellaris 400
Dimensions: 18 x 10 x 22cm
Max Aquarium Volume: 100L
Maximum Flow Rate: 400L/hr
Max Head Height: 1.0m
Filter Volume: 2.5 Litres
Power Requirements: 220 – 240V
Power Consumption: 6.7W
Suitable: Cold water, Tropical, Marine

Correct Disposal of this product



This marking indicates that this product should not be disposed with other household waste throughout the EU. To prevent harm to the environment or human health from uncontrolled waste disposal, recycle it responsibly to promote the sustainable reuse of material resources. To return your used device, please use the return and collection systems or contact the retailer where the product was purchased. They can take this product for environmental safe recycling.

Aqua One - Guarantee 2 + 1 Year

The additional 1 Year **Extended Guarantee** applies when you REGISTER online with Aqua One. Register your Extended Guarantee at www.aquaone.com.au

About this Guarantee

The Manufacturer or Distributor, of Aqua One goods, is collectively known herein as "Aqua One". Please refer to contact details for Aqua One below or on the applicable Aqua One website. Any product that is covered by its own Guarantee (as enclosed with the product) is subject to the conditions of that Guarantee.

Australian Guarantee

Important note: This guarantee applies in addition to the guarantees, rights and remedies conferred by the Australian Consumer Law and other applicable Commonwealth, State and Territory legislation. The guarantee does not exclude, affect or limit those guarantees, rights or remedies, except to the extent that their application may lawfully be excluded or limited.

In particular, our goods come with guarantees that cannot be excluded under the Australian Consumer Law. You are entitled to a replacement or refund for a major failure and for compensation for any other reasonably foreseeable loss or damage. You are also entitled to have the goods repaired or replaced if the goods fail to be of acceptable quality and the failure does not amount to a major failure.

International Guarantee

The benefits given to the purchaser, under Guarantee, are in addition to all other statutory rights and remedies which the purchaser has in respect of goods under legislation in the applicable country of purchase. This Guarantee shall not affect any such rights and should be read subject to such legislation.

1.0. Terms and Conditions of Guarantee.

- 1.1. Aqua One warrants to the purchaser, for 2 years from date of original purchase, to repair or replace goods where fault is found due to defective materials or faulty workmanship and where goods do not operate in accordance with the instructions.
- 1.2. All claims for repair or replacement must be made at place of purchase.
- 1.3. The original and dated Proof of Purchase (receipt) must be supplied with all goods claims. Please also provide this Guarantee where possible.
- 1.4. The Guarantee covers the Aquarium against gluing breakdown resulting in leakage.
- 1.5. All goods subject to claim under Guarantee should be prepared for transportation in the original packaging or other comparable packaging which offers the same degree of protection.
- 1.6. Where goods are repaired or replaced under Guarantee, these goods are Guaranteed for the remainder of either the original Guarantee or Extended Guarantee period.
- 1.7. Where claims on inspection reveal goods are in normal working order, Aqua One will request reimbursement of all reasonable costs incurred.

2.0. Other Terms and Conditions – Extended Guarantee

- 2.1. The Extended Guarantee period is for an additional 1 Year and commences on expiration of the standard guarantee period.
- 2.2. Application for Extended Guarantee is FREE of any registration cost to the purchaser on completion of the Extended Guarantee questionnaire which is found on the applicable Aqua One website (refer below).
- 2.3. Upon receipt and acceptance of the questionnaire, Aqua One will forward (by way of email) a Certificate of Extended Guarantee to the purchaser.
- 2.4. For more information on how we collect, hold, use and disclose personal information provided to us, please refer to our Privacy Statement on the Aqua One websites or write to our Privacy Officer, in your country of purchase.
- 2.5. Where Aqua One determines goods are being used in a manner contrary to the instructions, specifications or this Guarantee, Aqua One reserves the right to terminate Extended Guarantee for such goods and will provide written notice to the purchaser.

3.0. Exclusions and Limitations

Where permitted by local law, the following exclusions and limitations apply in regard to Guarantee:

- 3.1. Goods claims where fault is due to, but not limited by a) misuse b) neglect c) abuse d) fire or flood e) normal wear and tear f) accidental breakage g) Acts of God h) mains voltage fluctuation or supply problems i) connection to any voltage other than what is stated on the rating plate j) modification or tampering to electrical cord or plug, k) vermin, insects or foreign object l) liquid spillage or submersion of goods not designed to sustain such use or duress.
 - 3.2. Where inspections reveal goods are in normal working order including where noise or vibration is consistent with normal goods operation.
 - 3.3. Attempted repairs or modifications by unauthorised persons, including but not limited to the drilling of holes in the aquarium glass by unauthorised persons.
 - 3.4. Where the goods factory rating plate has been removed, altered, damaged or is rendered illegible.
 - 3.5. Where goods are not installed, operated or maintained in accordance with Aqua One's goods instructions, specifications or this Guarantee.
 - 3.6. Replacement or repair of worn consumables or replacement of lost goods, parts or components.
 - 3.7. Costs associated with goods transportation, removal, installation, postage or cost of insurance.
 - 3.8. Any damage incurred whilst installing, transporting or moving the goods.
 - 3.9. Subject to certain local statutory rights and obligations to the contrary, and this guarantee shall not affect those rights or obligations, where, to the full extent permitted by law: 1. all express and implied warranties and conditions under statute or general law, are expressly excluded and Aqua One, where permitted, will limit liability as follows and at Aqua One's option to: in regard to goods either a) the replacement of goods or supply of equivalent goods b) the repair of goods or the cost of replacing the goods or of acquiring equivalent goods OR in regard to services either c) the re-supply of services d) the cost to re-supply services.
2. Aqua One will not be liable for any loss or damage, including consequential loss or damage either directly or indirectly, or for any incidental expenses, of any kind, and in any way whatsoever.

The additional 1 Year Extended Guarantee applies when you REGISTER online with Aqua One. Register your Extended Guarantee at www.aquaone.com.au

(1) Consumables include items such as replacement light tubes.

Aqua One may be contacted in:
Australia
Kong's (Aust.) Pty. Limited
PO Box 863, Ingleburn
1890 NSW Australia
www.aquaone.com.au



Manufactured in China.
Designed in Australia by Aqua One.
Aqua One and *Aqua One Inspiring
Excellence in Fish Care!* are registered
trademarks or trademarks.

www.aquaone.com.au