

**EFX 100/200/300/400**



**aquamanta**<sup>TM</sup>  
the experts in aquatic technology



***Instruction Manual***

## Important Safeguards

**This appliance is not intended for use by persons (including children) with reduced physical, sensory or mental capabilities, or lack of experience and knowledge, unless they have been given supervision or instruction concerning use of the appliance by a person responsible for their safety.**

**Children should be supervised to ensure that they do not play with the appliance.**

**Warning: To guard against injury, basic safety precautions should be observed, including the following:**

1. Read and follow all safety instructions before using this appliance.
2. Danger: To avoid possible electric shocks, special care should be taken since water is employed in the use of aquarium equipment. For each of the following situations do not attempt repairs yourself. Return the appliance to an authorised service facility for service or discard the appliance.
  - a) If the filter falls into water, do not reach for it, unplug it and then retrieve it. If the electrical components of the appliance get wet, unplug the appliance immediately (non immersible equipment only).
  - b) If the filter shows any sign of abnormal water leakage, immediately unplug all electrical appliances from the power source.
  - c) Carefully examine the filter after installation. It should not be plugged in when there is water on parts which are not intended to be wet.
  - d) Do not operate any aquarium electrical appliance if they have a damaged cord or plug, or if they are malfunctioning, or dropped or damaged in any manner.
  - e) The power cord of the motor cannot be replaced. If the cord is damaged the motor should be scrapped.

A "drip loop" (See the diagram) should be arranged by the user for each cord connecting the electrical appliances in the aquarium to a receptacle. The drip loop is the part of the cord below the level of the receptacle. It is used to prevent water traveling along the cord and coming in contact with the receptacle.

If the plug or receptacle does get wet, do not unplug the appliance. Disconnect the fuse or circuit breaker that supplies the power to the appliance, then unplug and examine for presence of water in the receptacle.

3. Close supervision is necessary when the appliance is used by or near children.
4. Always unplug all electrical appliances in the aquarium from the electrical outlet, when not in use, before putting on or taking off parts, before any type of maintenance, or cleaning. Never yank the cord to pull it from the outlet. Grasp the plug and unplug to disconnect.

5. Do not use the filter for reasons other than the intended use. The use of attachments that are not recommended or sold by the filter manufacturer may cause the product to be unsafe. This is not recommended.

6. Do not install or store the filter where it will be exposed to weather or temperatures below freezing.

7. Make sure any component mounted on the aquarium is securely installed before operating it.

8. Read and observe all the important notices on the filter.

9. Ensure input voltage is the same voltage as your local power supply.

10. Ensure your hand is dry when turning the power switch on/off and when inserting/removing the power cord from the receptacle.

11. If you are in any doubt about the electrical installation or safety of this product you must consult a qualified electrician.

12. The filter (including the motor) is for indoor use only.

- a) Do not use the filter in water above 35°C.
- b) Always disconnect from electrical outlet before cleaning, maintenance or handling the filter.
- c) To protect against the risk of electrical shock, do not immerse the plug of the motor and motor in water or other liquid.

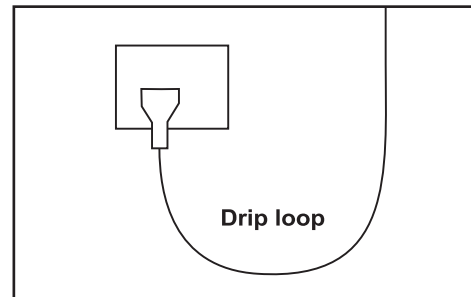

**For Guarantee Conditions, please refer to the Guarantee form that is enclosed with this product.**



**Warning:**

This appliance must not be disposed of together with domestic waste. It must be disposed of at an authorised centre set up for the recycling of electrical and electronic appliances. By collecting and recycling waste, you help save our natural resources. Please Make sure this product is disposed of in an environmentally friendly and safe way.

## Important Safeguards

### Connecting your appliance to the mains electricity supply - Country specific instructions.

#### United Kingdom

The plug supplied with this product is a sealed plug and we do not recommend removing or changing it. However, should the need arise, only a suitable plug should be connected using the following diagram 1

An approved earth leakage circuit breaker (RCCB) or otherwise known as an Residual circuit current device (RCCD) must be also fitted in the supply line.

**IF YOU ARE IN ANY DOUBT ABOUT INSTALLING YOUR APPLIANCE YOU SHOULD CONSULT A QUALIFIED ELECTRICIAN.**

#### Australia, New Zealand and Hong Kong

In Australia, New Zealand and Hong Kong all products are supplied with fitted plugs. This plug should **NOT** be tampered with in any way or removed. Removal or tampering with the plug invalidates our guarantee offered with this product.

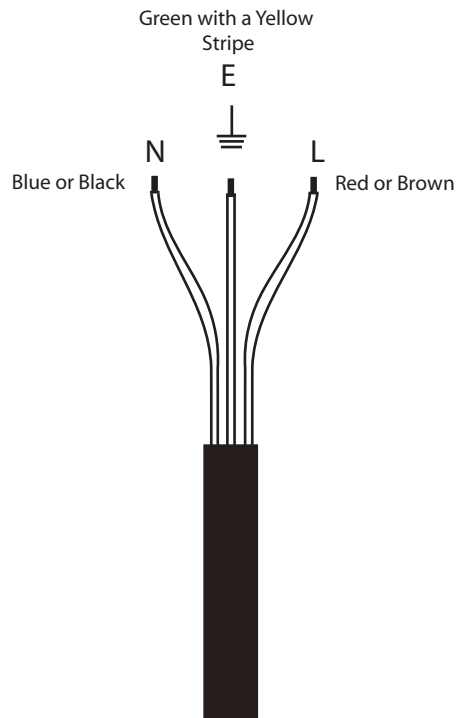

Diagram 1

## Before First Use / Preparation

Read and follow all the instructions, even if you feel you are familiar with the product and find a place to keep the instructions handy for future reference. Your attention is drawn particularly to the sections concerning **"IMPORTANT SAFEGUARDS"** and the **"Aquamanta GUARANTEE"**. Please ensure you retain your original purchase receipt in the event that guarantee service is required.

## Know Your Filter

EFX 100/200/300/400 External Power Filter

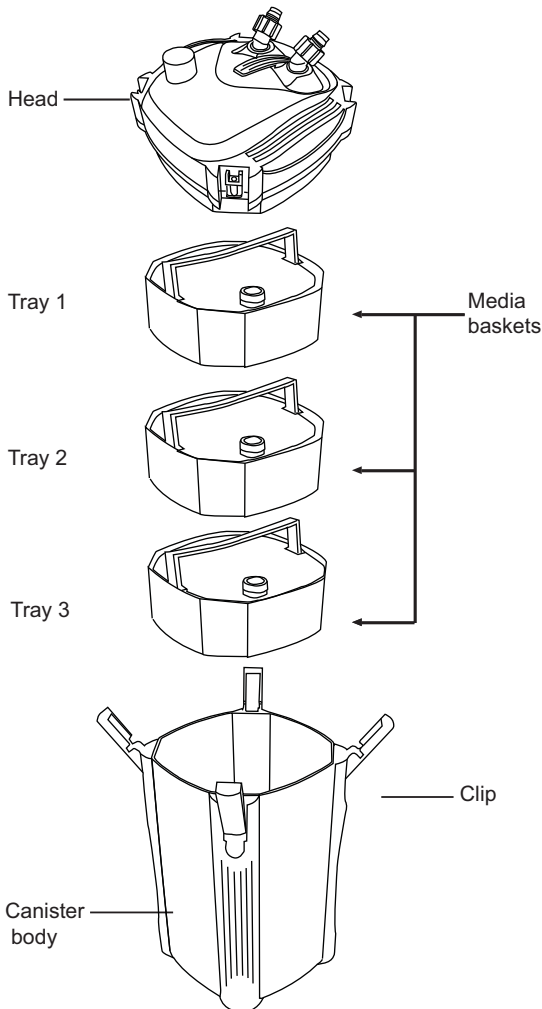

Please note EFX 100/300 have 2 media trays

Carefully unpack the product making sure you keep all the packing material until all the parts of the product have been found and the product has been assembled.

This product is shipped to you in a factory sealed carton. Should the product malfunction in any way or if the unit is damaged and requires replacement, contact the retailer where the product was purchased for inspection.

The plug supplied with this product is a sealed plug and we do not recommend removing or changing it.

### Replacement Parts & Filter Media

Use AquaManta Genuine Spare Parts Only. See your local AquaManta Dealer and look for the number listed below for the spare part you require.

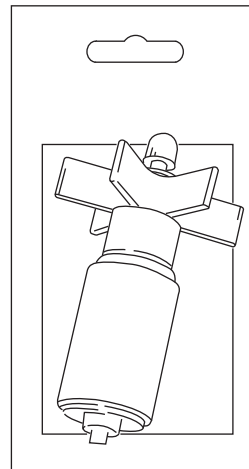

**Recomended Media Set Up**

# EFX 200/400

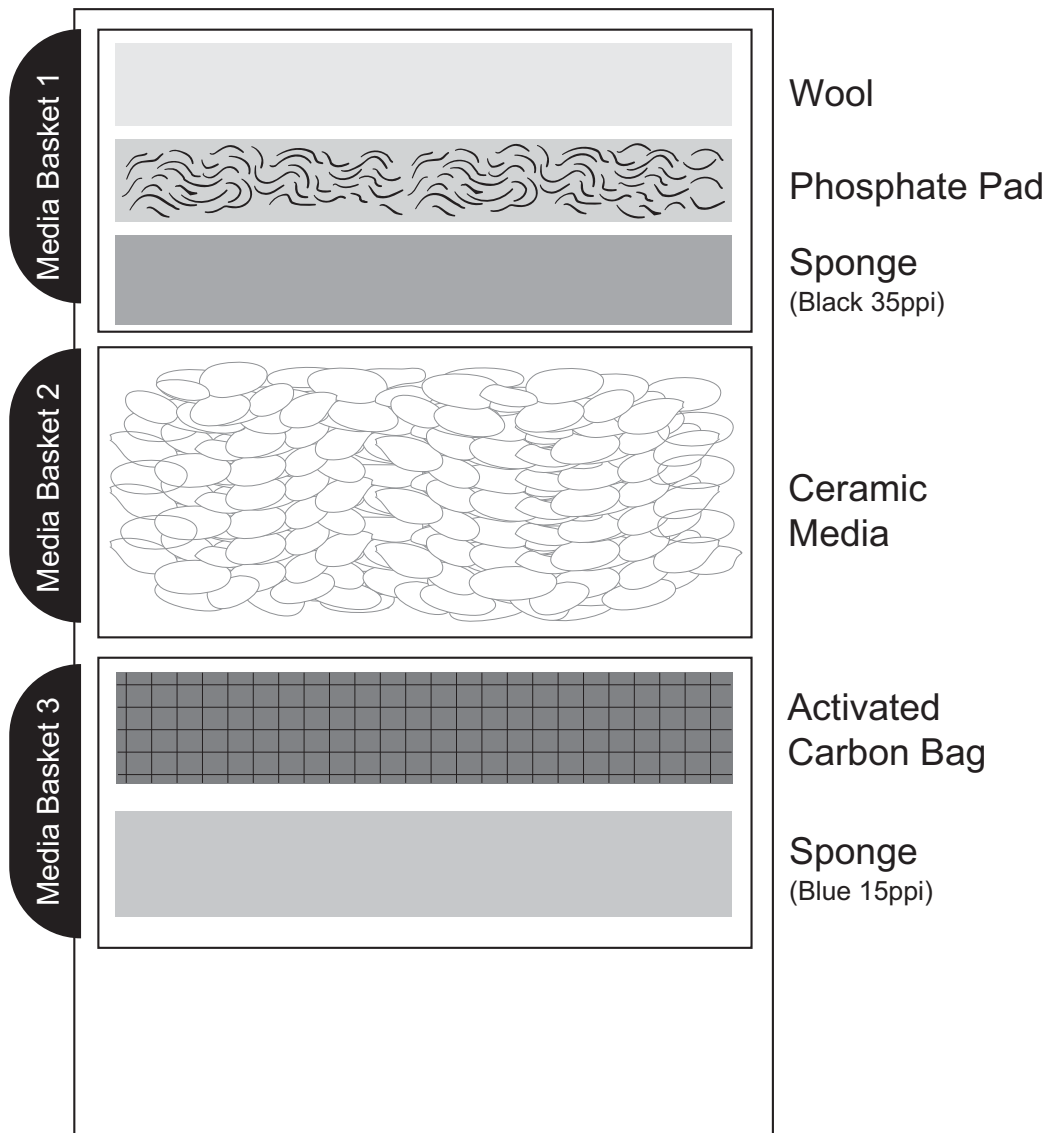

**Recommended Media Set Up**

# EFX 100/300

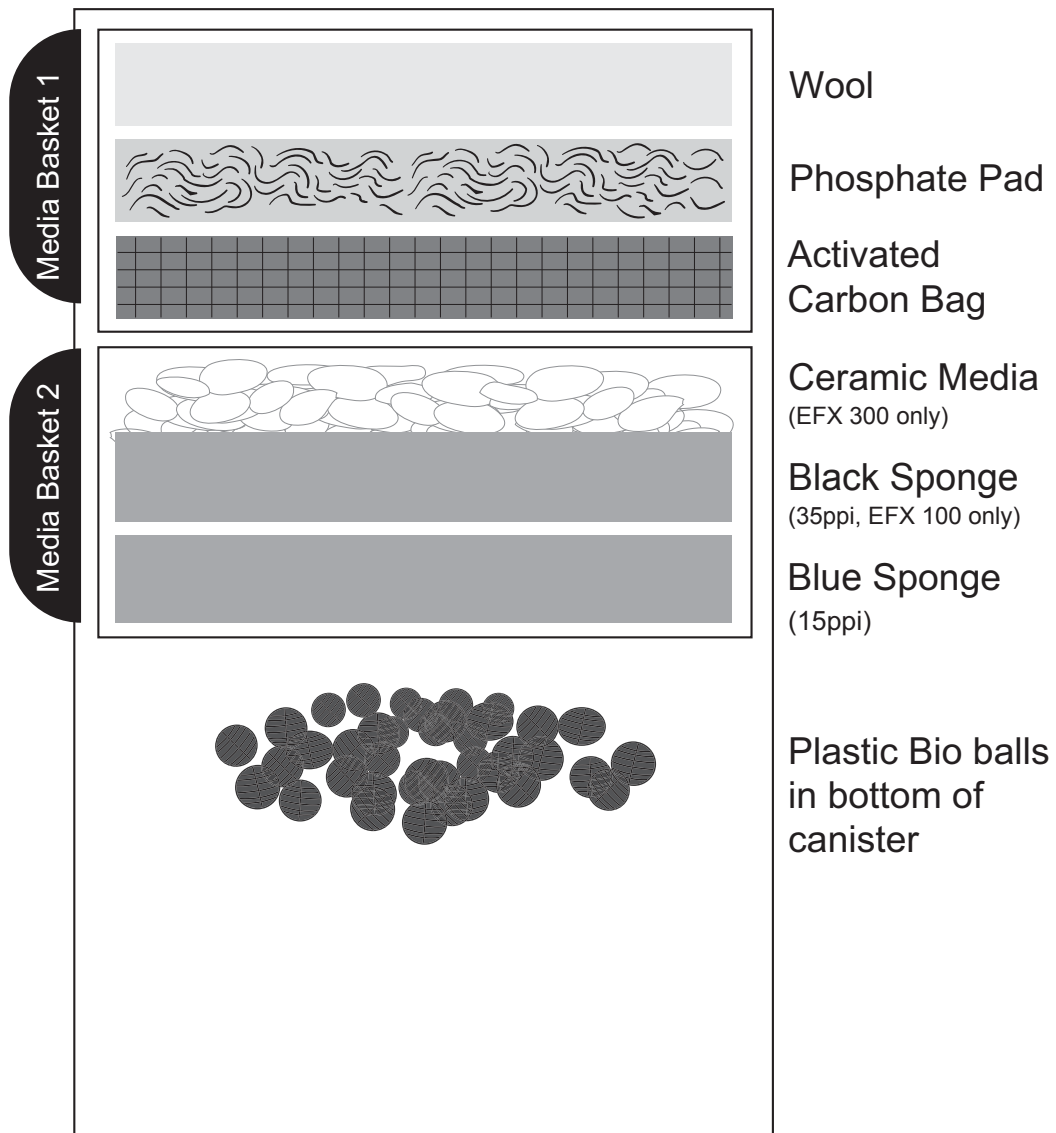

## Set Up Instructions

1. Remove the 2 boxed accessory packs and the filter unit from the box.

2. Open the filter unit. To do this release the 4 clips located on the corners of the filter. Fig 1

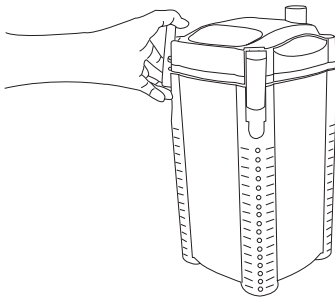

Fig 1

3. Lift the head unit off the canister body. Place it somewhere safe where it will not be stepped on or broken. Fig 2

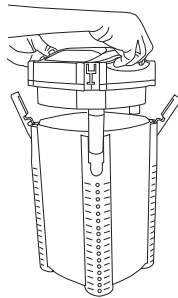

Fig 2

4. Take the canister body to the sink. Ensure the area is clean and free from detergents.

5. Remove the filter grid and the filter media baskets from the canister. Fig 3

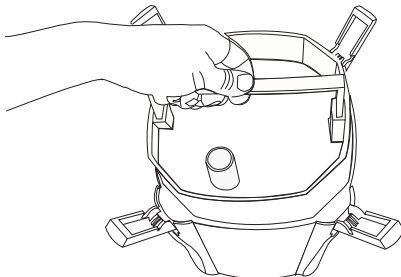

Fig 3

6. Follow the filter media setup instructions on the previous page which apply to your filter. Remember to remove all media from the plastic bags and rinse in tap water to remove excess dust. The simplest way to do this is empty the correct media into its basket and run tap water through it. Rinse the inside of the canister body in tap water. DO NOT USE ANY SOAPS OR DETERGENTS. Fig 4

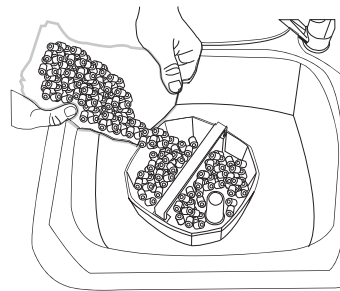

Fig 4

7. Once all the filter media and the canister has been washed and the sponges have been inserted into the filter baskets place the filter media baskets in the correct order (Refer to previous page) back into the canister body.

8. Ensure the filter grid is then placed back on top of the last filter basket. This is very important. Fig 6

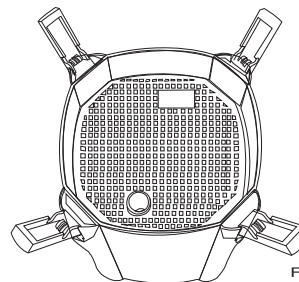

Fig 6





## Installation

1. Open the brown accessory boxes and remove all components from there plastic bags. You will find a set of taps and two pieces of hose. Screw the collar on the taps all the way in. (Clockwise)

2. Push one end of the hose over the hose tail on the tap. Push it on as far as possible. Fig 1

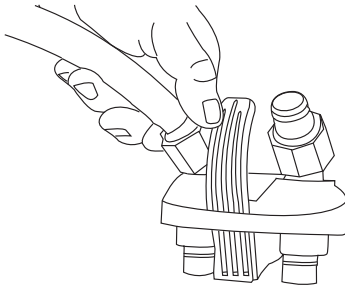

Fig 1

3. Turn the collar anti clock wise to lock in the hose. Do this on both pieces of hose.

4. be sure not to cross thread the tap as this may crack the seat and cause it to leak. Over tightening the tap will have the same effect. **NO TOOLS ARE REQUIRED. HAND TIGHT IS ENOUGH.**

5. Attach the taps to the top of the filter head and push the locking leaver down to lock the tap into position. Fig 2

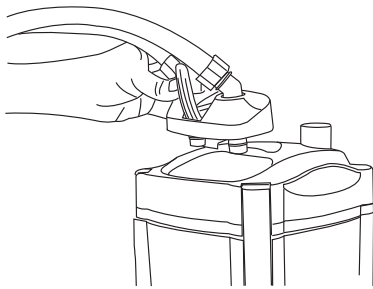
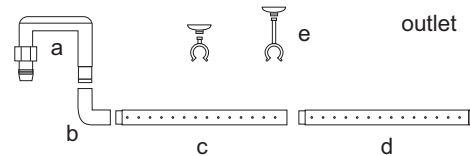

Fig 2

6. Place the canister in the desired position and feed the hose through the cabinet or stand.

7. Assemble the inlet and outlet. You will find you have 2 U pipes (a) which are identical.

8. Attach the elbow (b) on to the side of the U pipe which has the o-ring on it, Insert the



required number of spray bar (c) sections **DO NOT** make it too short. This will increase back pressure on the impeller and may cause the pump to become noisy! into the elbow (b). Press together firmly, Remember to place the spray bar section with the end cap (d) last. Attach suction cups (e) to the spray bar.

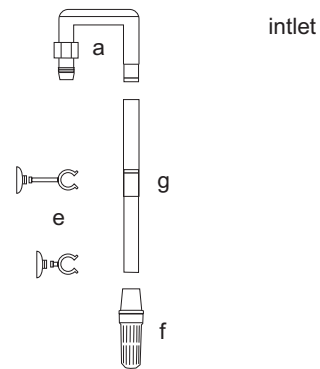

9. Use the second U pipe (a) for the inlet. Simply attach the strainer (f) to the longer side of the extension pipe (g). Then attach the extension pipe to the side of the U pipe with the o-ring on it. Complete the unit with the two Suction Cups (e).

10. You will notice in your accessory boxes long suction cup extensions. Use these if required to space either the spray bar or inlet from the glass.

11. Install the inlet first. (One with the Strainer) Place it into the aquarium, stick it to the glass wall. Fig 3

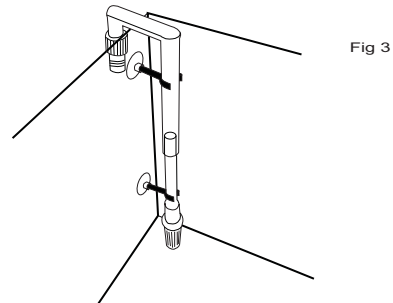
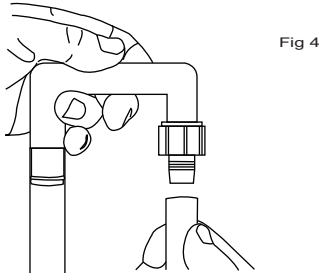

Fig 3

## Installation

12. Pull the hose from the inlet side of the filter up next to the inlet U pipe and line up. Fig 4



13. Measure a good 10cm more that what you need past the bottom of the U pipe.

14. Cut the hose using a sharp blade, try to cut it straight and be careful not to cut yourself.

15. Force the hose over the hose tail on the U pipe. Tighten, hand tighten only no tools are required. Fig 5

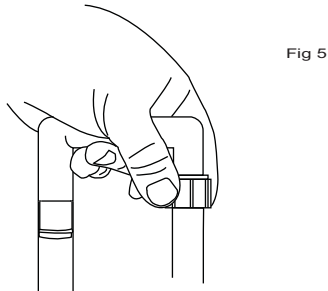

18. Repeat steps 14 to 17 for the outlet. Fig 6

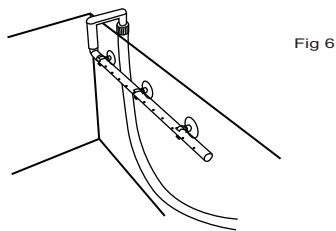

19. Place the Suction caps on the spray bar then attach it to the back or side of the aquarium. Fig 7

Please note the unit can be set up in many ways. Seek advice from you aquarium retailer for further possible setup options.

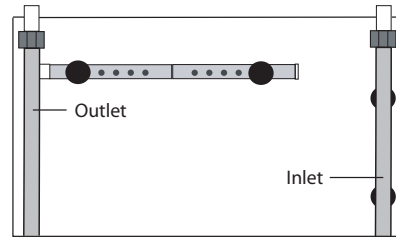

20. You are now ready to start your filter.

## Starting Your Filter

**NOTE:** Your aquarium must be filled with water to prime your filter.

Ensure your quick release tap connector is sitting correctly. Open the taps by pressing the Locing Lever down. Fig 1

**NOTE:** Once the filter is running, double check the fittings and seals for water tightness.

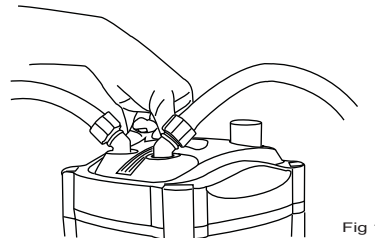

1. The Primer for your canister filter is located at the top of the head unit.

2. Press the primer down with your your thumb Fig 2

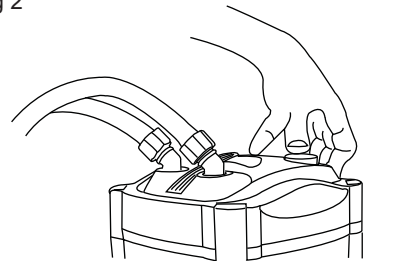

## Starting Your Filter

3. Depress all the way then release. Continue to pump the primer until the water flows down the inlet tube and begins to fill the canister.

4. Stop pumping and allow the canister to fill with water.

5. The filter is primed when the intake pipe and canister are completely filled and the water starts to travel up the outlet tube.

6. Wait until the canister is completely full of water. You will know this when water starts to rise up through the outlet hose. Ensure there are no leaks or water on parts of the filter which are not intended to be wet. Plug the unit into the power supply and switch on.

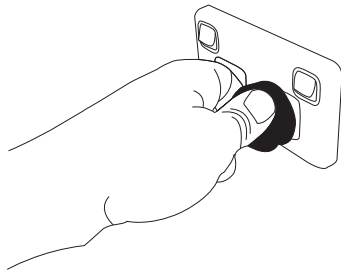

Fig 5

**NOTE:** If you require any further information about starting your filter please consult your Aquamanta retailer.

## Notes

---

---

---

---

---

---

---

---

---

---

## Cleaning Your Filter

**NOTE :** The Carbon Module and Phosphate Pad should be replaced every 4-6 weeks. Replacements are available from you local Aquamanta Dealer

1. Turn the canister filter off at the socket and unplug.

2. Place a towel or a shallow container under the canister unit. This will prevent any water spilling onto your cabinet or stand and damaging it.

3. Lift the Locking Lever to turn the taps off. Remove the quick release tap connector. Fig 1

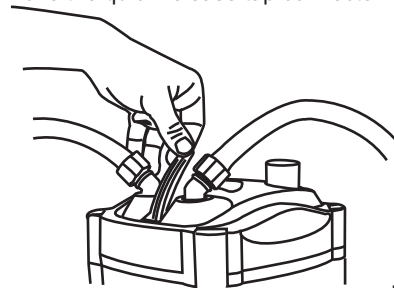

Fig 1

4. Fill a bucket with water from your aquarium and take it to the sink or wherever you intend to clean your filter. Keep in mind cleaning your filter can be messy, cleaning is recommended outside or at a sink. Ensure the area is clean and free from soaps and detergents.

5. Open the canister. Follow directions at the beginning of this manual under the section Set Up Instructions, points 2 to 5.

6. Extend the handles on the media baskets and remove them from the canister body.

7. Remove the filter sponges and the white wool from the media baskets and dunk the baskets with the Ceramic Media (Or any other type of biological media which may be in them) several times into the bucket. This will clear some of the dirt that can build up and clog the media and prevent the good bacteria which aid in breaking down pollutants in your aquarium from being killed by the chlorine in tap water.

8. Either replace or rinse the white wool pad using a high pressure hose. It should be replaced regularly or when it begins to deteriorate and can no longer be cleaned properly.

## Cleaning Your Filter

9. The sponges can also be rinsed in the bucket of aquarium water (Providing the water is not dirty. Replace if necessary) they will also require replacement eventually as over time they clog and prevent water from traveling through them easily.

10. Empty the bucket of aquarium water into the canister body. (Avoid tipping any dirt which may have settled on the bottom of the bucket into the canister)

11. Place the sponges back into their respective positions and reinsert the media baskets back into the canister body ensuring that each media basket sits nicely on top of the other.

12. The impeller should also be cleaned whenever the filter is disassembled.

13. Turn the head unit over and turn the impeller locking cover clockwise and remove it. Fig 2

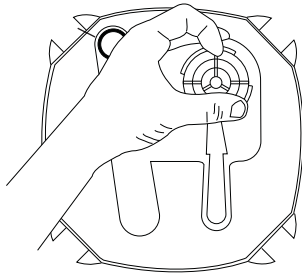

14. Then pull the impeller cap off and remove the impeller. Fig 3

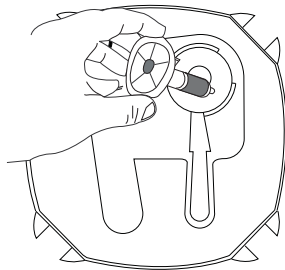

15. Clean the impeller chamber and the outlet channel using a double ended pipe brush. Fig 4

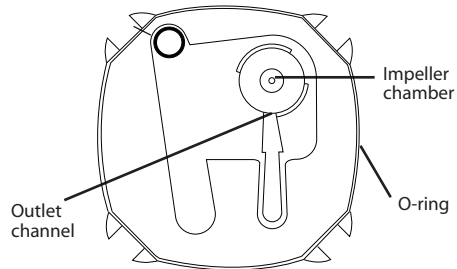

16. Use the double ended pipe brush and clean the inlet tube which runs through the base of the head unit. Fig 5

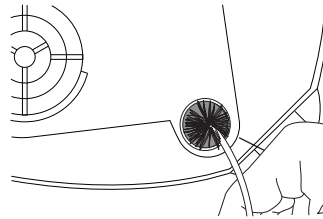

17. Pull the rubber end cap off the shaft of the impeller and run water through the hole in the middle of the impeller. Clean any debris which may have built up on the shaft off, along with any slime build up on the impeller. Fig 6

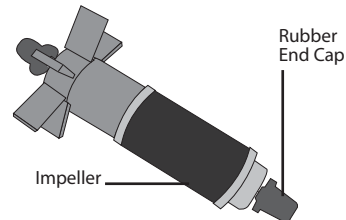

Fig 8

18. Put the impeller back together and ensure that it rotates freely on the shaft. Then reassemble the head unit, ensure there is no water on the power cord, plug the head unit in and turn on. Make certain the impeller is spinning. Turn it off. Reassemble the filter unit. Apply an aquarium safe lubricant to the O-ring on the head unit. This will provide a better water seal and make the removal of the head easier next time the filter has to be disassembled for maintenance. Fig 4





## Aquamanta - Guarantee 2 Year

### ATTENTION!

## PLEASE RETAIN YOUR PROOF OF PURCHASE AND GUARANTEE

Congratulations on your purchase of a quality Aquamanta product. This product will last you many years under normal usage.

#### About this Guarantee

The Manufacturer or Distributor, of Aquamanta goods, is collectively known herein as "Kong's (UK) Limited". Please refer to contact details for Aquamanta below or on the applicable Aquamanta website. Any product that is covered by its own Guarantee (as enclosed with the product) is subject to the conditions of that Guarantee.

The benefits given to the purchaser, under Guarantee, are in addition to all other statutory rights and remedies which the purchaser has in respect of goods under legislation in the applicable country of purchase. This Guarantee shall not affect any such rights and should be read subject to such legislation.

#### 1.0. Terms and Conditions of Guarantee.

- 1.1. Aquamanta warrants to the purchaser, for 2 Years from date of original purchase, to repair or replace goods where fault is found due to defective materials or faulty workmanship and where goods do not operate in accordance with the instructions.
- 1.2. All claims for repair or replacement must be made at place of purchase.
- 1.3. The original and dated Proof of Purchase (receipt) must be supplied with all goods claims. Please also provide this Guarantee where possible.
- 1.4. All goods subject to claim under Guarantee should be prepared for transportation in the original packaging or other comparable packaging which offers the same degree of protection.
- 1.5. Where goods are repaired or replaced under Guarantee, these goods are Guaranteed for the remainder of either the original Guarantee or Extended Guarantee period.
- 1.6. Where claims on inspection reveal goods are in normal working order, Aquamanta will request reimbursement of all reasonable costs incurred.

#### 2.0. Exclusions and Limitations

Where permitted by local law, the following exclusions and limitations apply in regard to the Guarantee:

- 2.1. Goods claims where fault is due to, but not limited by a) misuse b) neglect c) abuse d) fire or flood e) normal wear and tear f) accidental breakage g) Acts of God h) mains voltage fluctuation or supply problems i) connection to any voltage other than what is stated on the rating plate j) modification or tampering to electrical cord or plug, k) vermin, insects or foreign object l) liquid spillage or submersion of goods where goods are not designed to sustain such use or duress.
  - 3.2. Where inspections reveal goods are in normal working order including where noise or vibration is consistent with normal goods operation.
  - 3.3. Attempted repairs or modifications by unauthorised persons, including but not limited to modifications to the electrical lead or plug.
  - 3.4. Where the goods factory rating plate has been removed, altered, damaged or is rendered illegible.
  - 3.5. Where goods are not installed, operated or maintained in accordance with Aquamanta's goods instructions, specifications or this Guarantee.
  - 3.6. Replacement or repair of worn consumables<sup>(1)</sup> or replacement of lost goods, parts or components.
  - 3.7. Costs associated with goods transportation, removal, installation, postage or cost of insurance.
  - 3.8. Any damage incurred whilst installing, transporting or moving the goods.
  - 3.9. Subject to certain local statutory rights and obligations to the contrary, and this guarantee shall not affect those rights or obligations, where, to the full extent permitted by law:
    1. all express and implied warranties and conditions under statute or general law, are expressly excluded and Aquamanta, where permitted, will limit liability as follows and at Aquamanta's option to: in regard to goods either a) the replacement of goods or supply of equivalent goods b) the repair of goods or the cost of replacing the goods or of acquiring equivalent goods OR in regard to services either c) the re-supply of services d) the cost to re-supply services.
    2. Aquamanta will not be liable for any loss or damage, including consequential loss or damage either directly or indirectly, or for any incidental expenses, of any kind, and in any way whatsoever.
- (1) Consumables include items such as filter media, impellers, o-rings and other plastic components.

---

#### Aquamanta Registration Department

P.O BOX  
Romsey  
Hampshire  
SO51 0WW  
United Kingdom  
www.aquamanta.co.uk

